



Model: 966LGP

The Model 966LGP is manufactured to meet the demand for low pressure applications in harsh environments such as Offshore Oil & Gas applications.

Incorporating a precision capsule and movement assembly. Units are available for pressures as low as 25mBar for use on gases or fluids that are non-corrosive to Stainless Steel or Brass / Beryllium Copper.

The case is full safety pattern with a one piece solid baffle wall partition and a full blow out back making the unit acceptable in applications where the units may see excessive pressures in extreme conditions i.e bursting disc applications.

Meeting all the current National and International specifications and regulatory standards including EN837 and PED.

Size

100 mm (4") & 150mm (6")

Mounting

Direct, Surface and Flush

Case & Bezel

Rugged one-piece full Safety Pattern case to S3 standard with a solid baffle partition wall and full blow out back manufactured in 1.6mm thick, 316L stainless steel.

Scale Ranges

0 to 5 mbar to 0 to 500 mbar Pressure
Equivalent units of pressure / vacuum available
Single and dual scales are available

Pressure Element

5 to 45 mbar – 100mm Dial Size
50 to 700 mbar – 100mm and 150mm Dial Size

Overload

Units withstands overload pressure up to 130% of FSD
Overload & vacuum stops are fitted on the movement

Option: Mechanical overload clamps fitted internally to enable units to withstand up to 3x the max scale reading

Pressure Connection

3/8", 1/2" BSP
1/2" NPT
Other connections available, contact our Sales Dept

Accuracy Class

CL:1 1.5% of FSD

Temperature

Operating: -20 to +90 °C
Storage: -40 up to +100 °C
Options: for lower or higher operating temperatures, please contact our Sales Office

CAPSULE PRESSURE GAUGE LOW PRESSURE AND VACUUM



Dial

White Anodised Aluminium marked in black finish
Single or dual scale

Pointer

Stainless steel coloured black

Movement

Brass Construction

Window

3mm Laminated Safety Glass (Standard)
Option: Acrylic Plastic Window

Environmental Rating

IP67 as defined in EN 60 529

Traceability

All instruments are individually calibrated and have a unique Serial Number printed on the dial. A Certificate of Conformity Traceable to National Standards is supplied free of charge

Certification available

BS EN 10204 3.1B Material Certification
Point by Point Test Certificate

Safety

All units are manufactured to comply with EN 837-1, S3 specification and other regulatory standards including PED.

Installation Instructions

Refer to EN 837-2

Temperature Effect

Variation in indication caused by temperature shall not exceed $\pm 0.04 \times (t_2 - t_1)\%$ of the span where:
 t_1 is the reference ambient temperature in degrees Celsius
 t_2 is the ambient temperature in degrees Celsius

Dimensions

Model : 966LGP

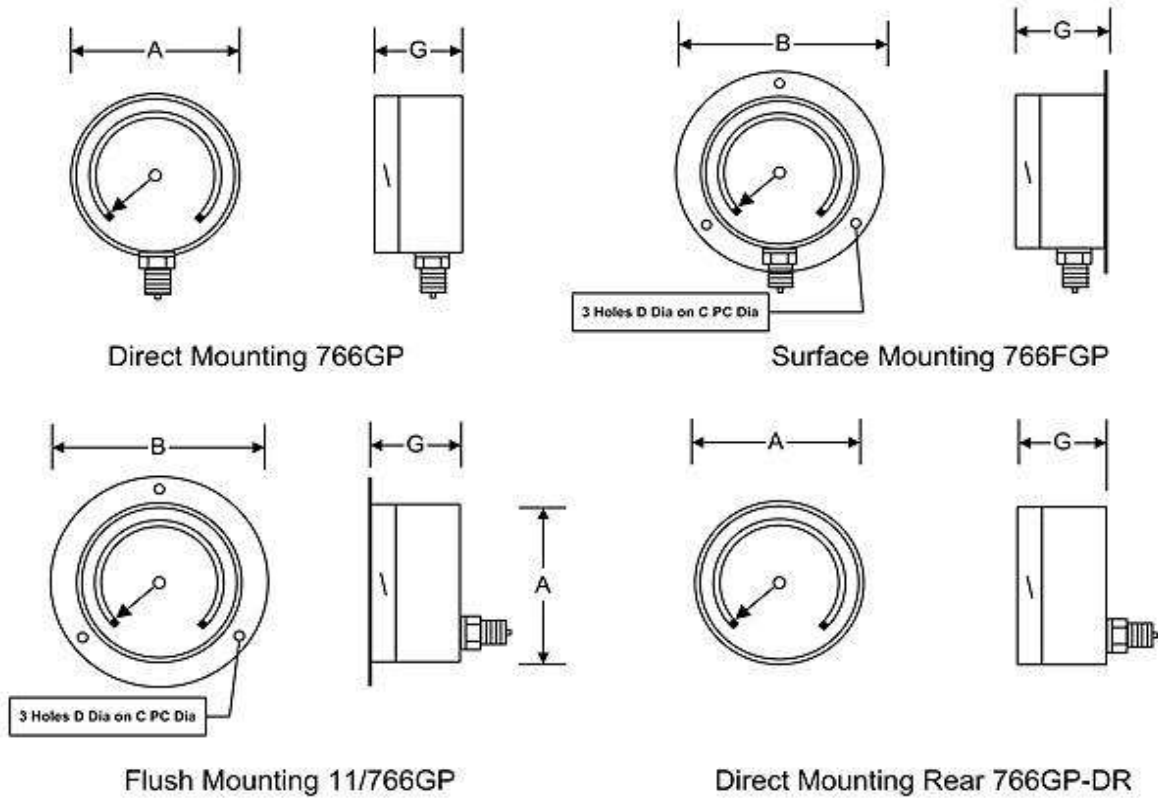

Model 966LGP uses the above 766GP case design and dimensions

Model No	A	B	C	D	G	Weight
100mm 966 (Dry Case)	105mm	131mm	118mm	6mm	52mm	0.7kg
150mm 966 (Dry Case)	162mm	183mm	168mm	6mm	53mm	1.34kg

Options

- Mounting : Flush mounting clamp fixing available
- Accuracy : 0.5% of FSD as defined in EN837-1
- Window : Acrylic Plastic Window
- Pointer : Micrometer adjustable Model 270

Accessories:

For high temperature applications such as steam, see our range of syphons and adaptors. – See separate Datasheet.

We can supply Needle, Ball or 2 Valve manifolds for the Model 766LGP – See separate Datasheet.

The manifolds in addition to allowing the instrument to operate normally allows the following: -

- a). Checking of gauge zero at line pressure.
- b). Complete isolation of the instrument.
- c). De-pressurisation of the instrument or controlled purging.
- d). Damping of pressure pulsations and surges.
- e). Inline calibration, allows in situation calibration

Specifications and dimensions in this leaflet, are subject to change without prior notice.



Budenberg Gauge Co. Ltd.
 Unit B2 Stuart Road
 Altrincham Business Park,
 Altrincham WA14 5GJ
 Tel: +44 161 777 7300.
 Email: sales@budenberg.co.uk

Budenberg Gauge Pvt. Ltd.
 299-300, IInd Main Road,
 Nehru Nagar,
 Old Mahabalipuram Road (OMR),
 Chennai - 600 096,
 Tamil Nadu , India
 Tel : +91 44 24541074
 Tel/Fax: +91 44 24541075
 Email: sales@budenberg-gauge.in

Budenberg Gauge Asia Pacific Ltd
 Unit 109 Cheung Fat Ind Bldg
 64-76 Larch St Tai Kok Tsui
 Kln
 Hong Kong
 Tel : +852 3709 0020
 Email: sales@budenberg-gauge.asia

Budenberg Middle East LLC
 PO Box 18980
 Dubai
 United Arab Emirates
 Tel: +971 4 2511670
 Email: sales@bme-me.com